



**Technical Manual for**  
**Internal GPIB Interface**  
**for PVS Series**  
**Power Supply**

## **WARRANTY**

This unit is guaranteed for one (1) year from the date of delivery against defects in material and workmanship. This does not apply to products damaged through accident, abuse, misuse, or unauthorized repair. The manufacturer shall not be liable for any special or consequential damage of any nature. The manufacturer will repair or replace the non-conforming product or issue credit, at its option, if the manufacturer's inspection establishes the existence of a defect. Packing, freight, insurance and other charges incurred in returning the defective products to the manufacturer will be paid by the purchaser. The manufacturer will pay return freight if the repaired unit is deemed to be under warranty. If any questions arise concerning the warranty, check with the manufacturer prior to taking any action.

When requesting information, assistance, or authorization, please state the serial number of the unit, available from the label on the unit. Give a brief description of the problem with the unit.

## **CONFIDENTIAL INFORMATION**

The information contained in this document is confidential and is the exclusive property of the manufacturer. It may not be disclosed to any person without the express written consent of the manufacturer.



## SAFETY PRECAUTIONS

The following safety precautions must be observed to avoid fire hazard, electrical shock, accidents, and other failures. Keep them in mind and make sure that all of them are observed properly. Kikusui assumes no liability against any damages or problems resulting from negligence of the precautions.

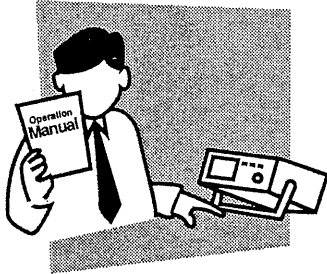

### Users

- This product must be used only by qualified personnel who understand the contents of this operating manual.
- If it is handled by unqualified personnel, personal injury may result. Be sure to handle it under supervision of qualified personnel (those who have electrical knowledge.)

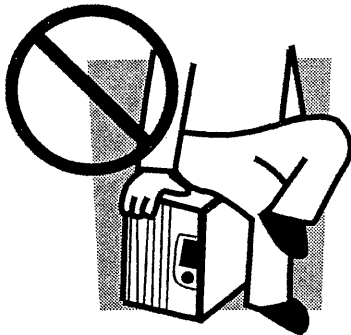

### Purposes of Use

- If the product is to be used for purposes not described in this manual, contact your Kikusui agent in advance.

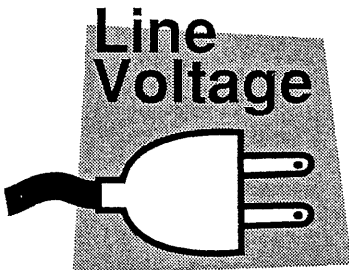

### Input Power

- Use the product with the specified input power voltage.
- For applying power, use the AC power cable provided. The shape of the plug differs according to the power voltage and local area standards. Use the cable which is suitable for the line voltage used.

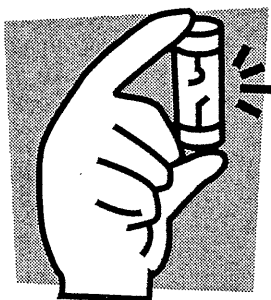

### Fuse

- With products with a fuse holder on the exterior surface, the fuse can be replaced with a new one.
- When replacing a fuse, use the one which has appropriate shape, ratings, and specifications.

## SAFETY PRECAUTIONS

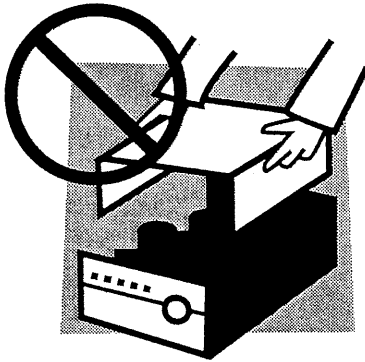

### Cover

- There are parts inside the product which may cause physical hazards.
- Do not remove the external cover. If the cover must be removed, contact your Kikusui agent in advance.

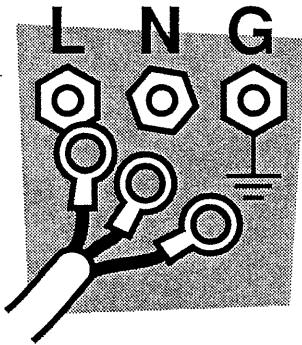

### Installation

- When installing products be sure to observe Section 2. Installation described in the operating manual for the power supply.
- To avoid electrical shock, connect the protective ground terminal to electrical ground (safety ground).
- When applying power to the products from a switchboard, be sure work is performed by a qualified and licensed electrician or is conducted under the direction of such a person.
- Be sure to use the AC power cable provided. Consult your Kikusui agent if a cable other than the one included is to be used for some reason.



### Relocation

- Turn off the power switch and then disconnect all cables when relocating the product.
- Use two or more persons when relocating the product which weights more than 20 kg. The weight of the products can be found on the rear panel of the product and/or in this operation manual.
- Use extra precautions such as using more people when relocating into or out of present locations including inclines or steps. Also handle carefully when relocating tall products as they can fall over easily.
- Be sure the operating manual is included when the product is relocated.

## SAFETY PRECAUTIONS

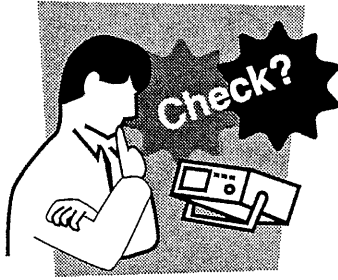

### Operations

- Check that the AC input voltage setting and the fuse rating are as specified and that there is no abnormality on the surface of the AC power cable. Be sure to unplug the AC power cable or stop applying power before checking.
- If any abnormality or failure is detected in the products, stop using it immediately. Unplug the AC power cable or disconnect the AC power cable from the switchboard. Be careful not to allow the product to be used before it is completely repaired.
- For output wiring or load cables, use connection cables with larger current capacity.
- Do not disassemble or modify the product. If it must be modified, contact your Kikusui agent.

### Maintenance and Checking

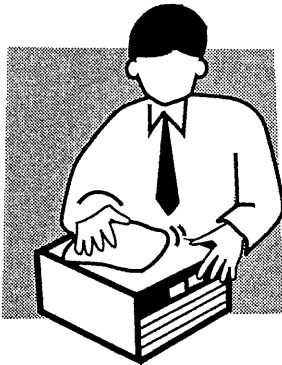

- To avoid electrical shock, be absolutely sure to unplug the AC power cable or stop applying power before performing maintenance or checking.
- Do not remove the cover when performing maintenance or checking. If the cover must be removed, contact your Kikusui agent in advance.
- To maintain performance and safe operation of the product, it is recommended that periodic checking, cleaning, and calibration be performed.

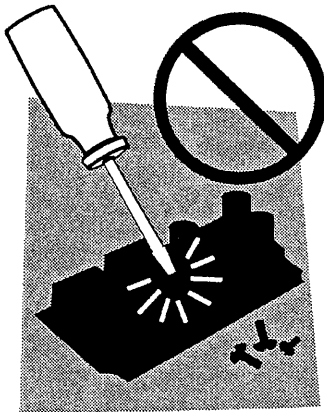

### Service

- Internal service is to be done by Kikusui service engineers. If the product must be adjusted or repaired, contact your Kikusui agent.

## ABOUT THIS MANUAL

This Technical Manual is for the internal GPIB interface, a microprocessor-controlled option card for all models of the PVS Series DC output power supply.

This manual is designed for the user who is familiar with basic electrical laws especially as they apply to the operation of power supplies. This implies a recognition of Constant Voltage and Constant Current operation modes and the control of input and output power, as well as the observance of safe techniques while effecting supply or pin connections and any changes in switch settings. The user should also have experience with a computer-based communications software package.

Refer to your power supply manual for installation, configuration, and operating procedures for the power supply.

The major sections of this manual are:

Section 1. Description	Describes the GPIB interface and lists its features.
Section 2. Installation and Configuration	Reviews initial inspection, gives a basic setup procedure and includes additional options for configuring the GPIB interface for operation.
Section 3. Operation	Lists the complete command set, status registers, and error codes.
Section 4. Calibration	Provides detailed procedures for voltage and current mode calibration as well as over voltage protection (OVP) calibration.
Appendix A. Specifications	Contains the electrical specifications for the power supply with the GPIB interface installed.
Appendix B. Sample Program	Shows a sample program, written in the Visual Basic programming language.

### Manual Revisions

The current release of this manual is listed below. Insert pages may update already printed manuals. Insert material incorporated into a reprinted manual may be identified with a change bar in the page margin.

Release 1.0 (2000-05-26)

### Warnings, Cautions, and Notes

Warnings, cautions, and notes are defined and formatted as presented below.

**WARNING**

Describes a potential hazard which could result in injury or death, or a procedure which, if not performed correctly, could result in injury or death.

**CAUTION**

Describes a procedure which, if not performed correctly, could result in damage to data, equipment, or systems.

**Note:** Describes additional operating information which may affect the performance of the equipment.

# CONTENTS

Safety Precautions ..... i  
 About This Manual ..... iv  
 Contents ..... v  
 List of Figures ..... vii  
 List of Tables ..... viii

## 1. DESCRIPTION

1.1 Introduction to the GPIB Interface ..... 1-1  
 1.2 Features and Functions ..... 1-2  
     1.2.1 Features ..... 1-2  
     1.2.2 Programmable Functions ..... 1-2  
     1.2.3 Readback Functions ..... 1-2

## 2. INSTALLATION AND CONFIGURATION

2.1 Introduction ..... 2-1  
 2.2 Initial Inspection ..... 2-1  
 2.3 Basic Setup Procedure ..... 2-3  
 2.4 IEEE-488 Primary Address Selection ..... 2-4  
 2.5 Power On Service Request (PON SRQ) ..... 2-4  
 2.6 Remote/Local Operation ..... 2-5  
     2.6.1 Remote/Local Mode Startup Selection ..... 2-5  
     2.6.2 Remote Mode Operation ..... 2-5  
     2.6.3 Local Mode Operation ..... 2-6  
     2.6.4 Setting Local Lockout ..... 2-6  
 2.7 IEEE-488 Controller Connection ..... 2-6  
 2.8 OVP and TTL Shutdown Operation ..... 2-7  
     2.8.1 OVP ..... 2-7  
     2.8.2 TTL Shutdown ..... 2-7  
 2.9 User Signals ..... 2-8  
     2.9.1 Connector J7 User Signals ..... 2-8  
     2.9.2 J7 Cable Connection ..... 2-9

## 3. OPERATION

3.1 Introduction ..... 3-1  
 3.2 GPIB Operation ..... 3-1  
     3.2.1 Multiline Control Functions ..... 3-1  
     3.2.2 Device Clear ..... 3-2  
     3.2.3 Device Trigger ..... 3-2  
     3.2.4 Local Lockout ..... 3-2  
     3.2.5 Service Request ..... 3-3  
     3.2.6 Serial Poll ..... 3-3  
 3.3 Command Syntax ..... 3-4  
     3.3.1 Manual Conventions ..... 3-4  
     3.3.2 Command Format and Parameters ..... 3-4  
     3.3.3 Order ..... 3-5  
 3.4 Command Summary ..... 3-6  
 3.5 Command Reference ..... 3-8  
 3.6 Accumulated Status, Status, and Fault Registers ..... 3-13  
 3.7 Error Codes ..... 3-14

**4. CALIBRATION**

4.1 Introduction .....4-1

4.2 Voltage Mode Calibration .....4-1

    4.2.1 Voltage Calibration Setup .....4-1

    4.2.2 Voltage Program Calibration Procedure .....4-2

    4.2.3 Voltage Readback Calibration Procedure .....4-2

4.3 Current Mode Calibration .....4-3

    4.3.1 Current Calibration Setup.....4-3

    4.3.2 Current Program Calibration Procedure.....4-3

    4.3.3 Current Readback Calibration Procedure.....4-4

4.4 Over Voltage Protection (OVP) Calibration .....4-4

**APPENDIX A. SPECIFICATIONS**

A.1 PVS 1200 Watt Series Supplies with GPIB Interface Installed .....A-1

A.2 PVS 2800 Watt Series Supplies with GPIB Interface Installed .....A-2

**APPENDIX B. SAMPLE PROGRAM**



## LIST OF FIGURES

Figure 1.1-1	Sample Configuration using GPIB Interface .....	1-1
Figure 2.2-1	Power Supply Front Panel with GPIB Interface Installed .....	2-2
Figure 2.2-2	GPIB Interface Subplate .....	2-2
Figure 2.9-1	User Signals J7 Connector .....	2-8
Figure 2.9-2	J7 User Signal Connector Circuit Block Diagram.....	2-8
Figure 2.9-3	User Cable with Ferrite Block.....	2-9
Figure 4.2-1	Voltage Calibration Setup .....	4-1
Figure 4.3-1	Current Calibration Setup .....	4-3

**LIST OF TABLES**

Table 2.3-1	Setup Procedure .....	2-3
Table 2.4-1	IEEE-488 Primary Address Selection .....	2-4
Table 2.5-1	SRQ Switch Selection .....	2-4
Table 2.6-1	Remote/Local Startup Selection Settings.....	2-5
Table 2.6-2	Remote Mode Power On Conditions .....	2-5
Table 3.2-1	IEEE-488.1 Interface Functions Implemented.....	3-1
Table 3.2-2	Serial Poll Status Register .....	3-3
Table 3.3-1	Command Parameters .....	3-5
Table 3.3-2	Floating Point Numbers .....	3-5
Table 3.4-1	Programming Commands.....	3-6
Table 3.4-2	Query Commands.....	3-6
Table 3.4-3	Calibration Commands.....	3-7
Table 3.4-4	Status Commands.....	3-7
Table 3.5-1	Command Reference.....	3-8
Table 3.6-1	Accumulated Status, Status, and Fault Registers .....	3-13
Table 3.7-1	Error Codes .....	3-14
Table A-1	Electrical Specifications for PVS 1200 Watt Series — 7.5 V to 6 0V Models .....	A-1
Table A-2	Electrical Specifications for PVS 1200 Watt Series — 100 V to 6 0 0V Models.....	A-1
Table A-1	Electrical Specifications for PVS 2800 Watt Series — 7.5 V to 6 0V Models .....	A-2
Table A-2	Electrical Specifications for PVS 2800 Watt Series — 100 V to 6 0 0V Models.....	A-2

# 1. DESCRIPTION

## 1.1 Introduction to the GPIB Interface

The internal GPIB interface card allows you to operate your power supply from a computer controller via the IEEE-488 communications bus. See Figure 1.1-1.

The GPIB interface allows complete remote programming of your power supply, including status reporting, settings query, and interrupt generation with user-designated fault conditions. Both the voltage and current output are precisely programmed directly in volts and amps with 16-bit resolution. Additionally, the built-in DVM and current shunt measure the actual power supply output and provide you with 16-bit readback. The programming command set is easy to use and includes software calibration commands. The interface card comes standard with several protection features such as programmable over voltage protection, foldback, load isolation signal, and soft limits.

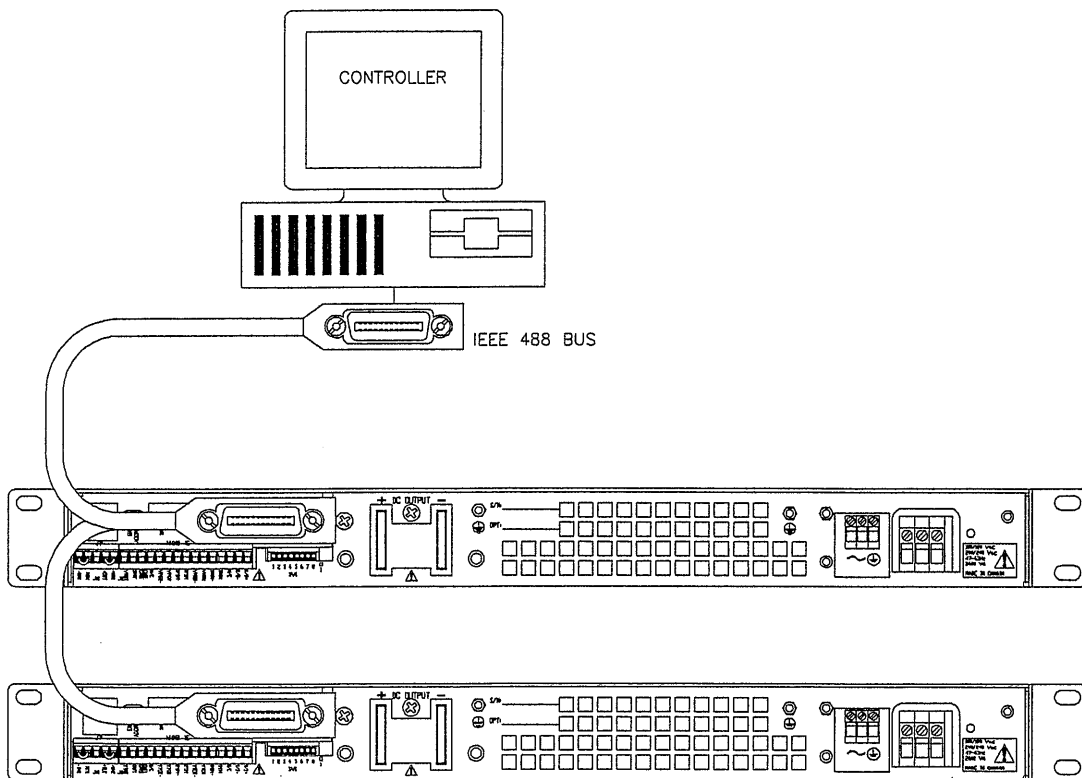

**Figure 1.1-1 Sample Configuration using GPIB Interface**  
(1200 watt DC power supplies shown.)

## 1.2 Features and Functions

### 1.2.1 Features

- 16-bit programming and readback of voltage and current
- Programmable soft limits for voltage and current
- Programmable over voltage protection with reset
- Isolated user-programmable signals such as fault, polarity, isolation, and auxiliary signals
- Foldback in CV or CC mode with reset
- Local Lockout capability
- Software calibration

### 1.2.2 Programmable Functions

- Output voltage and current
- Soft limits for voltage and current
- Overvoltage protection
- Output enable/disable
- Maskable fault interrupt
- Hold and trigger
- User-programmable output relay signals

### 1.2.3 Readback Functions

- Actual measured voltage and current
- Voltage and current settings
- Soft voltage and current limits
- Overvoltage protection setting
- Present and accumulated power supply status
- Programming error codes
- Fault codes
- Power supply model and version identification
- Firmware revision levels

## **2. INSTALLATION AND CONFIGURATION**

### **2.1 Introduction**

To use this product, you must have the following equipment:

- a compatible model of DC output power supply
- IEEE-488 connector and cable
- computer with an IEEE-488 interface
- Computer-based communications software package

### **2.2 Initial Inspection**

On first receiving your unit, perform a quick physical check.

- Ensure each package contains a power supply with its GPIB interface board installed, and manuals for the power supply and the GPIB interface. Any additional parts shipped with the power supply will be identified in the supply's documentation.
- Inspect the unit for any signs of physical damage such as scratches, cracks, or broken switches, connectors, or displays.

If the unit is damaged, save all packing materials and notify the carrier immediately.

## 2.2 Initial Inspection (continued)

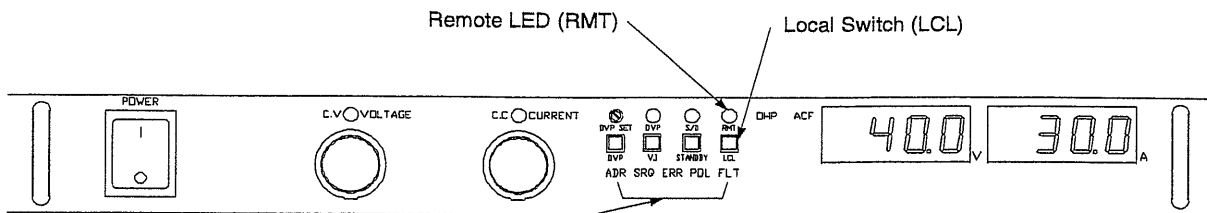

**Remote Programming LEDs:**

**Address LED (ADR)**

Indicates that the master controller is addressing the unit.

**Service Request LED (SRQ)**

Comes on at power up if the PON SRQ switch is set to on. You can enable the SRQ LED during normal operation with the SRQ command.

**Error LED (ERR)**

Indicates when a programming error has occurred. You can clear the ERR LED with an error query command.

**Fault LED (FLT)**

Indicates that a fault has occurred. The fault bit must be unmasked. Refer to the status register in Table 3.6-1. Momentarily lights if PON SRQ is set to on.

**Polarity LED (POL)**

Indicates that the polarity user line has been activated. See Section 2.9.1.

**Figure 2.2-1 Power Supply Front Panel with GPIB Interface Installed**  
(1200 watt power supply shown.)

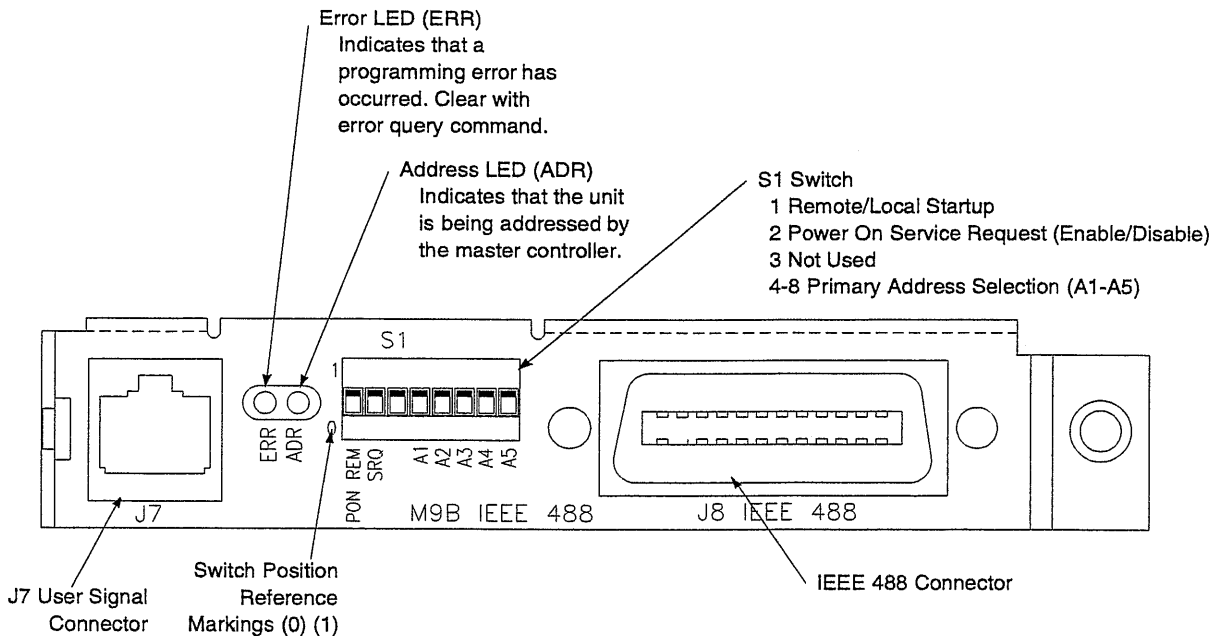

**Figure 2.2-2 GPIB Interface Subplate**  
(Located on rear panel of power supply.)

## 2.3 Basic Setup Procedure

This procedure can be used as a quick reference for those familiar with the configuration requirements for the GPIB interface as installed in the DC power supply. For those who want more information, each step refers to more detailed procedures located in subsequent sections. Execute each step of the procedure in the sequence given.

**Table 2.3-1 Setup Procedure**

Step #	Description	Action	Reference
1	Primary Address Selection	Use GPIB interface rear panel switches A1 to A5 to select a unique primary address. Setting the address identifies the power supply to the computer controller in a GPIB system.	See Section 2.4 IEEE-488 Primary Address Selection.
2	PON SRQ Selection	Use the rear panel SRQ switch to select the state of the Power ON Service Request	See Section 2.5 Power On Service Request (PON SRQ).
3	Remote/Local Operation	Use the rear panel PON REM switch to select remote or local startup of the power supply.	See Section 2.6 Remote/Local Operation.
4	IEEE-488 Controller Connection	Connect the IEEE-488 bus to the supply at connector J8.	See Section 2.7 IEEE-488 Controller Connection.
5	Power ON	Power on the unit. Before proceeding, check to ensure that the green RMT LED on the front panel is on.	See Section 2.9 User Signals for information about auxiliary connector J7 user signals.
6	Configure Computer Controller	Configure the controller to match the power supply identification and characteristics using one of the available programs.	One such program is IBCONF (Interface Bus Configuration) from National Instruments. This program is used here as an example only.
7	Test	Test the link by communicating with the power supply.	Example: VSET2;ISET1 This command string sets power supply voltage to 2V and its current limit to 1A. Example: ibwrt "vset2;set1" As above, using IBIC. <sup>1</sup>

1. This text uses National Instruments' IBIC (Interface Bus Interactive Control) program commands developed for their GPIB interface for computer controllers as examples only.

## 2.4 IEEE-488 Primary Address Selection

1. Assign a primary address to each power supply: Choose a number between 0 and 30 which is unique to your IEEE-488 bus, that is, different from other device addresses on the same bus.
2. Locate switch S1 on the GPIB interface rear panel. See Figure 2.2-2 for the interface subplate drawing.
3. Use switch positions A1 to A5 to set the primary address for the power supply. See Table 2.4-1.

**Table 2.4-1 IEEE-488 Primary Address Selection**

Address	A5	A4	A3	A2	A1	Address	A5	A4	A3	A2	A1
0	0 <sup>1</sup>	0	0	0	0	16	1	0	0	0	0
1	0	0	0	0	1	17	1	0	0	0	1
2	0	0	0	1	0	18	1	0	0	1	0
3	0	0	0	1	1	19	1	0	0	1	1
4	0	0	1	0	0	20	1	0	1	0	0
5	0	0	1	0	1	21	1	0	1	0	1
6	0	0	1	1	0	22	1	0	1	1	0
7	0	0	1	1	1	23	1	0	1	1	1
8	0	1	0	0	0	24	1	1	0	0	0
9	0	1	0	0	1	25	1	1	0	0	1
10	0	1	0	1	0	26	1	1	0	1	0
11	0	1	0	1	1	27	1	1	0	1	1
12	0	1	1	0	0	28	1	1	1	0	0
13	0	1	1	0	1	29	1	1	1	0	1
14	0	1	1	1	0	30	1	1	1	1	0
15	0	1	1	1	1						

1. Switch 0 = (OFF, OPEN); Switch 1 = (ON, CLOSED)

Note: Ensure that you assign one address to each GPIB controller board as well.

## 2.5 Power On Service Request (PON SRQ)

The Power ON Service Request (SRQ) switch is located on the GPIB subplate rear panel S1 switch. Enabling the SRQ switch causes the power supply to send a service request to the computer controller when the power supply is turned on or when it reinitializes after a momentary power interrupt. When the PON SRQ state is tripped, the front panel SRQ LED will also turn on. You can clear the service request and turn off the SRQ LED by performing a serial poll. See Section 3.5. for information about the SRQ command. Table 2.5-1 shows the condition of the SRQ switch in relation to the position reference markings on the rear panel subplate. The location of the switch and reference markings can be found in Figure 2.2-2.

**Table 2.5-1 SRQ Switch Selection**

Rear Panel SRQ Switch Position	PON SRQ State
0	PON SRQ Enabled
1	PON SRQ Disabled



## 2.6 Remote/Local Operation

### 2.6.1 Remote/Local Mode Startup Selection

You can start the power supply either in local mode or in remote mode by selecting the position of the rear panel power ON remote (PON REM) switch. Table 2.6-1 summarizes the switch settings in relation to the S1 switch markings on the rear panel subplate. No matter what mode you start the power supply in, you can toggle between local mode and remote mode by using a combination of the GPIB command set and the front panel local (LCL) switch. The subsequent sections describe in more detail remote mode and local mode operation. See Figure 2.2-2 for a drawing showing the position of the PON REM switch on the rear panel subplate.

**Table 2.6-1 Remote/Local Startup Selection Settings**

Switch Position	Setting
0	Remote Mode Power ON
1	Local Mode Power ON

While in remote mode, you can change to local mode operation by pressing the front panel LCL switch, except in local lockout state. To return to remote mode, set the unit to listener mode through the GPIB bus. When the unit is switched back to local mode, the output returns to the previous local mode settings.

### 2.6.2 Remote Mode Operation

With the rear panel PON REM switch set for remote model power ON, the power supply will start up in remote mode. The green RMT LED on the front panel will light, signaling that the power supply is under the control of the interface. To promote load safety, power on defaults ensure the output voltage and current limit are set to zero and OVP is set to 110% of maximum output voltage. From remote mode, you can switch to local mode by using the front panel LCL button (except in local lockout state) or by using the GPIB command set.

Powering up in remote mode will result in the default conditions in Table 2.6-2. See Section 3.5 Command Reference for more information about the commands.

**Table 2.6-2 Remote Mode Power On Conditions**

Condition	Default	Defaults for a 7.5-140 Model
Voltage	0 V	VSET 0
Current	0 A	ISET 0
Soft Voltage Limit	VMAX (see models)	VMAX 7.5
Soft Current Limit	IMAX (see models)	IMAX 140
OVP Trip Voltage	Model VMAX + 10%	OVSET 8.25
Foldback Protection	OFF	FOLD OFF
Output <sup>1</sup>	ON	OUT ON
Hold	OFF	HOLD OFF
Unmask	NONE	UNMASK NONE
Service Request Capability	OFF	SRQ OFF
AUXA	OFF	AUXA OFF
AUXB	OFF	AUXB OFF

1. If the OUT OFF command is sent when the unit is in local mode, the unit will switch to remote mode and shut down the output. However, when the unit is switched back to local mode, the output will be live.

You can return to local mode from remote mode by pressing the front panel LCL switch (except in local lockout state).

### 2.6.3 Local Mode Operation

If the rear panel PON REM switch is set to local startup, the power supply will power ON in local mode. Power supply control is at the front panel. From local mode, you can go to remote mode by setting the device to listener mode through the GPIB bus. You can return to local mode using the GPIB GTL command or by pressing the front panel LCL switch. You can disable the front panel LCL switch by using the GPIB LLO command. For an example of local lockout, see Section 2.6.4.

<b>Example:</b> <code>ibfind "devname"</code>	Address the unit (devname or device name as configured originally with <code>ibconf</code> ).
<code>ibloc</code>	Set unit to local mode.
<code>ibwrt "id?"</code>	Any access to the unit now puts it back to remote mode.
<code>ibloc</code>	Toggle back to local mode.

### 2.6.4 Setting Local Lockout

The GPIB command set allows you to disable the front panel local (LCL) switch from toggling the power supply to local mode. With local lockout in effect you can only use the GPIB Go To Local (GTL) command to change the operating state of the power supply to local mode.

<b>Example:</b> <code>ibfind GPIB0</code>	Address the computer controller.
<code>ibsic</code>	Put the controller in charge by sending an Interface Clear.
<code>ibsre1</code>	Asserts Remote Enable.
<code>ibcmd "?_@\x11"</code>	Send commands (UNL, UNT, MTA0, LLO) in ASCII.
<code>ibfind "devname"</code>	Address the unit (devname or device name as configured originally with <code>ibconf</code> ).
<code>ibloc</code>	Set unit to local mode

Note: To disable Local Lockout, use the IBIC `ibsre0` command.

## 2.7 IEEE-488 Controller Connection

Use an approved IEEE-488 connector and cable when connecting the GPIB interface to your IEEE-488 GPIB network. The IEEE-488 connector uses mating connector J8 on the rear panel. Refer to the GPIB interface subplate drawing in Figure 2.2-2.

## 2.8 OVP and TTL Shutdown Operation

### 2.8.1 OVP

Over voltage protection (OVP) on the GPIB interface is set at the factory for remote software operation. When operating the power supply in remote mode, you control the OVP trip level using the OVSET software command. If you return the power supply to local operation by using the GPIB software commands or the by the front panel LCL switch, control of the OVP trip level changes from software control to the front panel OVP potentiometer. The default OVP trip level is set as 110% of the power supply's rated output voltage. See Table 2.6-2 for a complete list of remote power ON default settings.

### 2.8.2 TTL Shutdown

You can use the Shutdown function to disable or enable the supply's output. Disabling the supply using TTL shutdown allows you to make adjustments to the load or to the power supply without shutting down the power supply. With the GPIB interface installed, TTL shutdown is activated by a TTL signal to Pin 1 of the J7 connector on the interface subplate. The shutdown user line uses a 0-5 Vdc TTL input with a high signal range of 2.2-5.0 Vdc. The current range of the shutdown line is 1-10 mA. See Figure 2.9-2 for a schematic of the J7 connector containing the shutdown user line.

## 2.9 User Signals

### 2.9.1 Connector J7 User Signals

Auxiliary connector J7, located on the GPIB interface rear panel, provides several signals to increase your operating control of the supply. These signals are dependent on the operator's design and uses. The operation of the J7 signal requires that you provide external Vcc and ground. Use a standard 8-position telephone jack and data cable to connect to J7. To locate the connector, refer to the GPIB interface subplate drawing in Figure 2.2-2. See Figure 2.9-1 for pin descriptions. The J7 outputs can sink a current of 5 mA each. Figure 2.9-2 shows the portion of the option board schematic which contains the J7 connector. Use the schematic as a reference when making input or output connections.

- J7-1 External TTL shutdown input signal (See Section 2.8.2)
- J7-2 Polarity signal, open collector  
(asserted by VSET -x)
- J7-3 Isolation signal, open collector  
(asserted by OUT OFF)
- J7-4 Fault signal, open collector  
(asserted when bit set in fault register)
- J7-5 External Vcc, 15 V maximum  
(supplied by connecting and operating an external source)
- J7-6 External ground and shutdown return  
(supplied by connecting and operating an external source)
- J7-7 Open collector user signal  
(asserted by AUXA ON)
- J7-8 Open collector user signal J  
(asserted by AUXB ON)

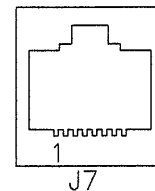

Figure 2.9-1 User Signals J7 Connector

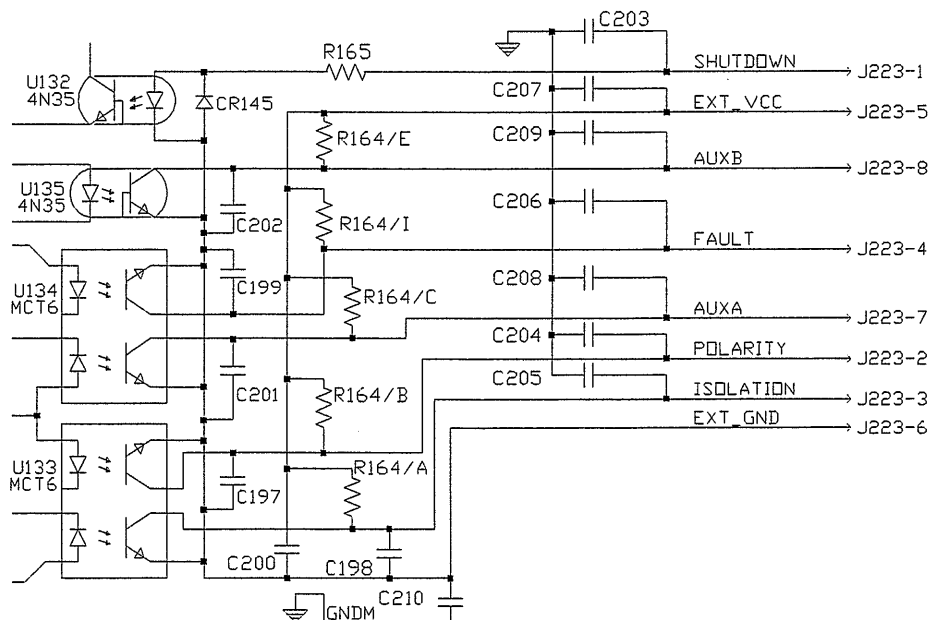

Figure 2.9-2 J7 User Signal Connector Circuit Block Diagram

### 2.9.2 J7 Cable Connection

Use a standard 8-position telephone jack and data cable to connect to J7. Add a ferrite block to reduce radiated emission. The one-inch square ferrite block with built-in housing clip is packaged and shipped with the power supply interface card.

To install the ferrite block:

1. Position the block no more than 5cm (2") from the power supply end of the J7 user cable.
2. Open the ferrite block housing.
3. Loop the cable through the ferrite block. See Figure 2.9-3.
4. Close the housing clip.

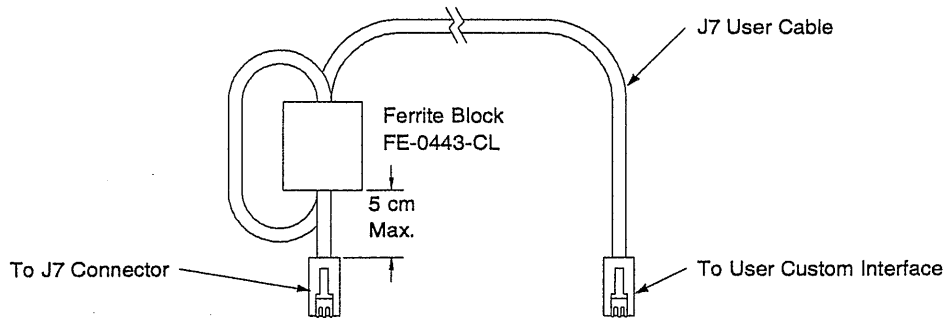

**Figure 2.9-3 User Cable with Ferrite Block**

## 3. OPERATION

### 3.1 Introduction

This section covers GPIB interface programming, starting with IEEE-488 functions, continuing with an extensive set of device-dependent commands, and, finally, providing error codes, and status and fault register information.

### 3.2 GPIB Operation

A GPIB interface controller card enables you to control an IEEE-488 bus system via computer, identifying which of its interconnected devices are to send and receive data. Interconnected devices could include programmable AC or DC power supplies, oscilloscopes, signal generators, digital voltmeters, universal counters, readouts, relays, and printers.

Use the GPIB interface to relay GPIB instructions from a computer controller to a power supply located at a selected IEEE-488 address and then to return responses from the power supply to the computer. You will also use the computer controller to issue device-dependent commands such as output voltage level and status queries.

**Note:** This text employs National Instruments' IBIC (Interface Bus Interactive Control) program commands developed for their GPIB board for computer controllers as examples only.

**Table 3.2-1 IEEE-488.1 Interface Functions Implemented**

	<b>Mnemonic</b>	<b>Capability</b>	<b>Description</b>
<b>Multiline Control Functions</b>	SH1	Source Handshake	Device must properly transfer a multiline message.
	AH1	Acceptor Handshake	Device must properly receive remote multiline messages.
	T6	Talker	Device must be able to transmit.
	L4	Listener	Device must receive commands and data.
<b>Interface Functions</b>	DC1	Device Clear	Device can be initialized to a previously determined state.
	DT1	Device Trigger	A device function can be initiated by a talker on the bus.
	E1	Open Collector Drivers	Describes the type of electrical drivers in a device.
	RL1	Remote/Local	Device must be able to operate from front panel and via remote information from bus.
	SR1	Service Request	Device can asynchronously request service from controller.
	SP1	Serial Poll	All talkers on the bus assume a serial poll mode. Each device when addressed will provide an 8-bit word of status information.

#### 3.2.1 Multiline Control Functions

The GPIB interface and the computer controller implement the Acceptor Handshake, Source Handshake, Listener, and Talker functions.

### 3.2.2 Device Clear

The power supply will implement Device Clear regardless of whether it is in local or remote control. Device Clear is typically used to send all or selected devices to a known state with a single command. The power supply will be set to Initial (Power On) Conditions after Device Clear.

**Example:**

<code>ibfind "devname"</code>	Address the unit (devname or device name as configured originally with <code>ibconf</code> )
<code>ibclr</code>	Low level command directed to entire bus, or
<code>ibwrt"clr"</code>	Device-dependent command directed to a specific device.

### 3.2.3 Device Trigger

Device Trigger will implement the most recently programmed values whether the unit is in local or remote control. If the power supply is in local mode, the new values will be implemented when it is switched from local to remote control. Device Trigger is typically used to synchronize the operation of a number of addressed devices.

**Example:** Use HOLD Command to set values to be executed when triggered. See Section 3.5.

Then use:

<code>ibfind "devname"</code>	Address the unit (devname or device name as configured originally with <code>ibconf</code> )
<code>ibtrg</code>	Command directed to entire bus, or
<code>ibwrt"trg"</code>	Command directed to a specific device.

### 3.2.4 Local Lockout

Send Local Lockout from the computer controller to override the front panel LCL (local) switch and ensure that the supply operates in remote mode. See Section 2.6.4 for more information.

**Example:**

<code>ibfind GPIB0</code>	Address the computer controller.
<code>ibsic</code>	Put the controller in charge by sending an Interface Clear.
<code>ibsre1</code>	Asserts Remote Enable.
<code>ibcmd "?_@\x11"</code>	Send commands (UNL, UNT, MTA0, LLO) in ASCII.

**Note:** To disable Local Lockout, use `ibsre0` in place of `ibsre1` in the example.

**3.2.5 Service Request**

Service request is a uniline message asserted by the power supply at power on and for fault conditions. Ten(10) power supply conditions are defined as faults: CV, CC, OV, OTP, SD, FOLD, ERR, ACF, OPF, and SNSP. See Section 3.6 Accumulated Status, Status, and Fault Registers for more information. Power ON (PON) can also be flagged in the fault register if the supply's rear panel power on service request (PON SRQ) switch is set to ON. See Section 2.5 Power On Service Request (PON SRQ).

**3.2.6 Serial Poll**

In a serial poll, the controller polls each device.

**Example:** `ibrsp` Return serial poll byte.

The power supply responds with a 8-bit status byte defined as follows:

**Table 3.2-2 Serial Poll Status Register**

Bit Position	Decimal Weight	Description	Reset By
0 (LSB)	1	<b>Fault</b> — Set when any bit in the fault register is set by a fault condition in the supply. See also Section 3.6 Accumulated Status, Status, and Fault Registers.	FAULT? query to reset
1	2	Not used	
2	4	Not used	
3	8	Not used	
4	16	<b>Ready</b> — Set when power supply is ready to accept commands.	Power supply, during command processing period
5	32	<b>Error (ERR)</b> — Set when ERR bit asserted in status register. See also Section 3.6 Accumulated Status, Status, and Fault Registers.	ERR? query
6	64	<b>Request Service (SRQ)</b> — Set when power supply requests service.	Serial Poll
7 (MSB)	128	<b>Power On (PON)</b> — Set when unit initializes at power on.	CLR or Device Clear



### 3.3 Command Syntax

#### 3.3.1 Manual Conventions

The manual uses these conventions when displaying command information. These characters are not part of the command but are used to denote parameters used with the command.

- < > (angle brackets)      Angle brackets enclose a parameter. Do not include the angle brackets in the command line you send to the computer.
- / (slash)                      Separates two alternative parameters. When a slash separates two parameters, you can use either parameter to achieve the same result.

Example: <1/ON>

Entering 1 or ON will achieve the same result.

COMPUTER ENTRY      Words typed on the computer are shown in Arial text, full capitals.

#### 3.3.2 Command Format and Parameters

The device-dependent language for the GPIB Interface consists of commands and parameters. A command is a one-word code which either gives instructions to the interface or asks for information from the interface. A command may be followed by one or more parameters, a short code that changes the state of the power supply or the state of the bit register. Table 3.3-1 lists the parameters that affect the command set.

##### Format:

COMMAND or COMMAND <parameter> or COMMAND <parameter>,<parameter>

- You can enter commands in upper or lower case lettering.

Example:      MASK FOLD = mask fold

- Do not further abbreviate command names or parameters.

Example:      MASK FOLD ¼ MK FOLD  
                  MASK FOLD ¼ MASK FD

- Use a space between the command and the first parameter. Any number of consecutive spaces is treated as one space. Numeric data may contain leading spaces. Embedded spaces between digits or between a digit and a decimal point are not accepted.

Example:      MASK FOLD = MASK    FOLD  
                  VOUT 3.4 = VOUT    3.4  
                  VOUT 3.4 ¼ VOUT 3.    4

- Use commas between parameters in those commands with more than one parameter, and between mnemonic parameters as in the MASK and UNMASK commands. Only one comma is allowed and it may be preceded or followed by any number of spaces.

Example:      MASK CV, OV, FOLD

3.3.2 Command Format and Parameters (continued)

Table 3.3-1 Command Parameters

Parameter	Description	Form
<current>, <lhi>, <llo>	The current in amps or milliamps. If no unit is given, the default unit is amps.	<float> <float>A <float>mA
<time>	The time in seconds or milliseconds. If no unit is given, the default unit is seconds.	<float> <float>s <float>ms
<voltage>, <Vlo>, <Vhi>	The voltage in volts or millivolts. If no unit is given, the default unit is volts.	<float> <float>V <float>mV
<mnemonics>	A combination of CV, CC, OV, OT, SD, FOLD, ERR, PON, REM, ACF, OPF, and SNSP. See MASK and UNMASK commands in the command reference for use of the ALL and NONE parameters.	See registers in Section 3.6 Accumulated Status, Status, and Fault Registers.
<state>	The state of a binary condition.	<1/ON, 0/OFF>

**Floating Point Number <float>**

Variables sent with command parameters are floating point numbers. Table 3.3-2 Floating Point Numbers defines the structure of floating point numbers for use with the software commands.

Table 3.3-2 Floating Point Numbers

Floating Number Definition	Example
The floating point number has four significant figures.	1.234 +1.234
A floating point number can have one decimal point.	0.123 1.2 123.4
Scientific Notation Use E or e after the number for a base ten exponent. An integer of either sign must follow an exponent.	123.0E-1 1.2E-1 10.00E+1

3.3.3 Order

You may send commands in any order, keeping in mind that only those commands received after a HOLD and before a TRG (trigger) will be released by the TRG command. In addition, only these commands received after a supply disable and before a RST (reset) or OUT ON command will be released by the RST command or the OUT command. Commands are executed in the order they are received.

### 3.4 Command Summary

Use these commands to control the operation of the supply. They are listed here in order of function such as PROGRAMMING, QUERY, CALIBRATION, and STATUS commands. See Section 3.5 Command Reference for more detailed information about each command and its use.

**Table 3.4-1 Programming Commands**

Command	Description
AUXA	Selects the state of the AUXA output signal on the J7-7 connector.
AUXB	Selects the state of the AUXB output signal on the J7-8 connector.
CLR	Initializes the power supply to its Power ON (PON) state.
DLY	Sets a programmable time delay which is executed by the supply before reporting fault conditions after a new output voltage or current is specified.
FOLD	Sets foldback mode for the supply.
HOLD	Enables or disables voltage/current setting hold mode for the supply.
IMAX	Sets an upper soft limit on the programmed output current for the supply.
ISET	Sets the output current of the supply in amps (default) or in milliamps.
OUT	Enables or disables voltage/current output for the supply.
OVSET	Sets the over voltage protection trip point for the supply in volts (default) or in millivolts.
RST	Resets the supply to the present voltage and current settings if the output is disabled by OVP or foldback protection.
SRQ	Enables or disables the power supply's ability to generate a service request.
TRG	Implements programmed voltage and current settings which had been in hold mode.
VMAX	Sets an upper soft limit on the supply's programmed output voltage.
VSET	Sets the output voltage of the power supply in volts (default) or in millivolts.

**Table 3.4-2 Query Commands**

Command	Description
AUXA?	Asks for the state of the set value for the AUXA command
AUXB?	Asks for the state of the set value for the AUXB command
CMODE?	Asks for the power supply's calibration mode status.
DLY?	Asks for the programmable time delay setting before the supply reports fault conditions.
ERR?	Asks for the most recent remote programming error which occurred in the supply since the last time the error query command (ERR?) was used.
FOLD?	Asks for the supply's present foldback setting.
HOLD?	Asks for the present hold mode setting.
ID?	Asks for the power supply's model name and master EPROM version.
IMAX?	Asks for the supply's soft current limit setting.
IOUT?	Measures the supply's actual current output.
ISET?	Asks for the supply's present output current limit setting.
OUT?	Asks for the present enabled/disabled status of the supply's output.
OVSET?	Asks for the supply's present over voltage protection limit.
ROM?	Asks for the version number of the master and slave EPROMs on the interface PCB.
SRQ?	Asks for the present enabled/disabled status of the IEEE-488 Service Requests generated by the supply.
VMAX?	Asks for the supply's soft voltage limit setting.
VOUT?	Measures the supply's actual voltage output.
VSET?	Asks for the supply's present output voltage setting.

### 3.4 Command Summary (continued)

**Table 3.4-3 Calibration Commands**

<b>Command</b>	<b>Description</b>
CMODE	Places the supply into calibration mode.
IDATA	Calculates the slope and intercept for current programming.
IHI	Sets the current output to the high calibration point.
ILO	Sets the current output to the low calibration point.
IRDAT	Calculates the slope and intercept for current readback.
IRHI	Sets the current output to the high readback point.
IRLO	Sets the current output to the low readback point.
OVCAL	Calibrates the over voltage protection (OVP).
VDATA	Calculates the slope and intercept for voltage programming.
VHI	Sets the voltage output to the high calibration point.
VLO	Sets the voltage output to the low calibration point.
VRDAT	Calculates the slope and intercept for voltage readback.
VRHI	Sets the voltage output to the high readback point.
VRLO	Sets the voltage output to the low readback point.

**Table 3.4-4 Status Commands**

<b>Command</b>	<b>Description</b>
ASTS?	Asks for the supply's accumulated status register.
FAULT?	Asks for the supply's fault register for the status preset operating conditions.
MASK	Prevents the supply's previously unmasked operating conditions from setting bits in the fault register.
STS?	Asks for the supply's present status register.
UNMASK	Enables you to select those supply's operating conditions that you are most interested in monitoring for fault occurrence.
UNMASK?	Asks for the supply's fault conditions which are currently enabled (unmasked).

## 3.5 Command Reference

**Table 3.5-1 Command Reference**

Command	Description
ASTS?	Asks for the supply's accumulated status register. The accumulated status register stores any bit that was entered in the status register since the accumulated status query command (ASTS?) was last used, regardless of whether the condition still exists. The accumulated status register has the same bits, weights, and conditions as the status register. See Section 3.6 Accumulated Status, Status, and Fault Registers. The ASTS? query clears the status register. Response: ASTS <status mask> where status mask is the decimal equivalent of the total bit weights for the operating conditions as listed in the status register.
AUXA <1/ON>,<0/OFF>	Controls the AUXA output signal level at rear panel connector J7-7. Active low. Initial value: AUXA 0
AUXA?	Asks for the present set value of the AUXA output signal. Response: AUXA 0 (OFF) AUXA 1 (ON)
AUXB <1/ON>,<0/OFF>	Controls the AUXB output signal level at rear panel connector J7-8. Active low. Initial value: AUXB 0
AUXB?	Asks for the present set value of the AUXB output signal. Response: AUXB 0 (OFF) AUXB 1 (ON)
CLR	Initializes the power supply to its power ON condition. CLR will not reset CMODE.
CMODE <1/ON>,<0/OFF>	CMODE ON places the power supply into calibration mode for processing calibration commands. Initial value: CMODE OFF or CMODE 0
CMODE?	Asks for the power supply's calibration mode status. Response: CMODE 0 (disabled) 1 (enabled)
DLY <seconds>	Sets a programmable time delay employed by the supply before reporting fault conditions. The power supply uses the time delay after receiving a new output voltage or current setting via VSET or ISET, or after receiving RST, TRG, or OUT ON commands. During the time delay, the power supply disables CV, CC, and FOLD conditions from generating faults, preventing possible nuisance foldback if the supply momentarily switches modes while changing an output setting. Setting range: 0.000 to 32.000 seconds with programmable increments/decrements of 0.032 seconds within this range. Actual delay time will be more than the delay setting due to the effects of the bus, microprocessor, power supply, and load.
DLY?	Asks for the setting of the programmable time delay before the supply reports fault conditions. Response: DLY <seconds>
ERR?	Asks for the most recent remote programming error. When the power supply detects a programming error, it lights the ERR LED and sets the ERR bit in the accumulated status and fault registers. If the error bit has been masked using the MASK command, then the ERR bit in the registers will not set. Once an error is detected, the remaining portion of the command line is discarded. An error query clears the ERR bit in the accumulated status register. See Section 3.7 Error Codes. Response: ERR <error number> Example: ERR 0 (if no error)
FAULT?	Asks for the state of the fault register. A bit is set in the fault register when a fault arises for that condition. lists the conditions which activate a fault bit. You can use the MASK command to disable bits from being set in the fault register. When a bit is set in the fault register it also asserts a signal on the J7-4 user signal line. You can tie the J7-4 fault line signal to the power supply's own External Shutdown user line, J7-1, so that the shutdown signal goes low (active) in the case of a user-defined fault. The FAULT? query clears bits in the supply's fault register and fault line. Response: FAULT <fault mask> where fault mask is the decimal equivalent of the total bit weights for the operating conditions as listed in the fault register. See Section 3.6 Accumulated Status, Status, and Fault Registers.

Continued on next page.

Table 3.5-1 Command Reference (continued)

Command	Description
FOLD <2/CC>, <1/CV>, <0/OFF>	Sets foldback mode for the supply. Foldback protection disables the power supply output when the output enters the fold condition. Reset with the RST command. Example: Specify FOLD 1 or FOLD CV (Constant Voltage) when you want the supply to operate in Constant Current mode and have foldback protection disable the output if the supply switches to Constant Voltage mode. Initial value: FOLD 0/OFF
FOLD?	Asks for the supply's present foldback setting. Response: FOLD <mode> where mode is: 0 (OFF) or 1 (CV or Constant Voltage mode) or 2 (CC or Constant Current mode)
HOLD <1/ON>,<0/OFF>	Enables or disables voltage/current setting hold mode for the supply. When HOLD ON is specified, hold mode is enabled so that all voltage and current settings which would normally be implemented by the supply are held until a TRG (trigger) command is received. This feature allows you to synchronize the operation of several supplies. Initial value: HOLD OFF or HOLD 0
HOLD?	Asks for the present hold mode setting. Response: HOLD 0 (OFF or disabled) or 1 (ON or enabled)
ID?	Asks for the power supply model and the master EPROM version. Response: ID <model name><version>
IDATA <llo>,<lhi>	Calculates and records the slope and offset for programmed current using ILO and IHI data. Set CMODE ON before using this command. See also the calibration procedures in Section 4. <llo> and <lhi> are in <current> format.
IHI	In response to this command, the power supply sends a programmed current value to the output terminal. This value is at the high end of the power supply's current range and is read by an external device connected as part of the calibration procedure. Refer to this value as IHI and record it to use as input with the IDATA command. Set CMODE ON before using this command. See also the calibration procedures in Section 4.
ILO	In response to this command, the power supply sends a programmed current value to the output terminal. This value is at the low end of the power supply's current range and is read by an external device connected as part of the calibration procedure. Refer to this value as ILO and record it to use as input with the IDATA command. Set CMODE ON before using this command. See also the calibration procedures in Section 4.
IMAX <current>	Sets an upper soft limit on the supply's programmed output current. If the soft limit is exceeded, or if the soft limit value is lower than the present output current setting, the supply will ignore the command, turn on the E RRLED, and set the ERR bit in the bit registers. Range: 0 to model maximum output current (IMAX) Initial value: model IMAX
IMAX?	Asks for the supply's soft current limit setting. Response: IMAX <current>
IOUT?	Measures the supply's actual current output using the built-in current readback circuitry. Response: IOUT <current>
IRDAT <llo>,<lhi>	Calculates and records the slope and offset for readback voltage using IRLO and IRHI data. Set CMODE ON before using this command. See also the calibration procedures in Section 4. <llo> and <lhi> are in <current> format.
IRHI	The power supply outputs a current value to an external device connected as part of the calibration procedure and records a current readback value internally. These values are at the high end of the programmed current range. Refer to the output value as IRHI and record it to use as input with the IRDAT command. Set CMODE ON before using this command. See also the calibration procedures in Section 4.

Continued on next page.

Table 3.5-1 Command Reference (continued)

Command	Description
IRLO	The power supply outputs a current value to an external device connected as part of the calibration procedure and records a current readback value internally. These values are at the low end of the programmed current range. Refer to the output value as IRLO and record it to use as input with the IRDAT command. Set CMODE ON before using this command. See also the calibration procedures in Section 4.
ISET <current>	Sets the power supply's output current in amps (default) or in milliamps. This programmed current is the actual output in CC mode or the current limit in CV mode. Range: 0 to model maximum output current (IMAX) Initial value: 0 amps
ISET?	Asks for the supply's present output current setting. Does not apply to current settings which are being held. See HOLD command. Response: ISET <current>
MASK <mnemonics>	Disables the supply's previously unmasked operating conditions from setting bits in the fault and status registers. See Section 3.6. Mnemonics are separated from each other by commas and may be sent in any order. Mnemonics: CV, CC, OV, OT, SD, FOLD, ERR, PON, REM, ACF, OPF, SNSP Note: UNMASK NONE = MASK ALL (Initial value) MASK NONE = UNMASK ALL
OUT <1/ON>,<0/OFF>	Enables or disables the supply's voltage/current output. The supply will continue to accept new commands while the output is disabled but these will not be implemented until OUT ON or OUT 1 is received. OUT ON is the default setting. When you start the supply in remote mode, the output is enabled. OUT OFF (or OUT 0) also sets the isolation signal on the rear panel J7 connector, line 3. You can use the to trip external relays to isolate the power supply from the load. Initial value: OUT ON (or OUT 1) for output enabled
OUT?	Asks for the present enabled/disabled status of the supply's output voltage/current. Response: OUT 1 output enabled or 0 output disabled
OVCAL	Causes the master controller to perform automatic calibration of the supply's over voltage protection circuitry. Set CMODE ON before using this command. Ensure that jumper J65 on the GPIB Interface PCB is connected for remote operation.
OVSET <voltage>	Sets the supply's over voltage protection trip point in volts (default) or in millivolts. If the trip point is exceeded, or if the trip point value is lower than the present output voltage setting, the supply will ignore the command, turn on the ERRLED, and set the ERR bit in the accumulated status register. Reset with the RST command. Range: 0 to 110% of model maximum output voltage (VMAX) Initial value: 110% of model VMAX
OVSET?	Asks for the supply's present over voltage protection limit. Response: OVSET <voltage>
ROM?	Asks for the version number of the master and slave EPROMs located on the interface PCB. Response: ROM M:<version> S:<version>
RST	Resets the supply to present voltage and current settings if the output is disabled by over voltage or foldback protection. Output values may be changed via VSET, ISET, and OVSET while the unit is disabled, but those values will not take effect until RST is applied.
SRQ <1/ON>,<0/OFF>	SRQ ON enables the supply to respond to a variety of fault conditions with a request for service to the IEEE-488 bus controller. With SRQ ON, the SRQ line will be asserted true whenever the FAU bit in the supply's serial poll register changes from 0 to 1. Therefore, the mask register, in addition to specifying which conditions set the FAU bit, also determines which conditions can generate service requests. Ten power supply conditions are defined as faults: CB, CC, OV, OTP, SD, ERR, FOLD, ACF, OPF, SNSP. Use the FAULT? query to discover which condition caused the service request. See Section 3.6 Accumulated Status, Status, and Fault Registers. A request for service at Power ON (PON SRQ) is set via a rear panel switch on the supply. See Section 2.5 Power On Service Request (PON SRQ). SRQ remains disabled until the FAULT bit in the serial poll register is cleared by a FAULT? query.

Continued on next page.

Table 3.5-1 Command Reference (continued)

Command	Description
SRQ?	Asks for the supply's present ability to generate service requests. Response: SRQ 0 (disabled) 1 (enabled)
STS?	Asks for the supply's present status register. Status conditions are stored in the status register. Each bit represents a separate condition. When the condition is true, the corresponding bit is 1 (true). Bits remain set in the status register as long as the condition is true. See Section 3.6 Accumulated Status, Status, and Fault Registers. Response: STS <status mask> where status mask is the decimal equivalent of the total bit weights for the operating conditions as listed in the status register.
TRG	Implements programmed voltage and current settings which had been in hold mode. The supply operates with previous values until the TRG (trigger) command is sent.
UNMASK <mnemonics>	Enables you to select the supply operating conditions that you are most interested in monitoring for fault occurrence. Mnemonics describing the conditions are separated from each other by commas, and may be sent in any order. Specifying one or more mnemonics which describe the conditions (or the decimal equivalent of their total bit weight) enables the selected conditions to set bits in the supply's fault and status registers during operation. A bit is set in the fault register when the corresponding bit in the status register changes from 0 to 1 and the corresponding bit in the mask register is 1. See Section 3.6 Accumulated Status, Status, and Fault Registers. Mnemonics: CV, CC, OV, OT, SD, FOLD, ERR, PON, REM, ACF, OPF, SNSP, ALL, NONE Initial value: UNMASK NONE
UNMASK?	Asks for the supply's fault conditions which are currently enabled (unmasked). Response: UNMASK <fault mask> where fault mask is the decimal equivalent of the total bit weights for the operating conditions as listed in the status and fault registers. See Section 3.6 Accumulated Status, Status, and Fault Registers.
VDATA <Vlo>,<Vhi>	Calculates and records the slope and offset for programmed voltage using VLO and VHI data. Set CMODE ON before using this command. See also the calibration procedures in Section 4. <Vlo> and <Vhi> are in <voltage> format.
VHI	In response to this command, the power supply sends a programmed voltage value to the output terminal. This value is at the high end of the power supply's voltage range and is read by an external device connected as part of the calibration procedure. Refer to this value as VHI and record it to use as input with the VDATA command. Set CMODE ON before using this command. See also the calibration procedures in Section 4.
VLO	In response to this command, the power supply sends a programmed voltage value to the output terminal. This value is at the low end of the power supply's voltage range and is read by an external voltmeter connected as part of the calibration procedure. Refer to this value as VLO and record it to use as input with the VDATA command. Set CMODE ON before using this command. See also the calibration procedures in Section 4.
VMAX <voltage>	Sets an upper soft limit on the supply's programmed output voltage. If the soft limit is exceeded, or if the soft limit value is lower than the present output voltage setting, the supply will ignore the command, turn on the ERR LED, and set the ERR bit in the accumulated status register. Range: 0 to model maximum output voltage (VMAX) Initial value: model VMAX
VMAX?	Asks for the supply's soft voltage limit setting. Response: VMAX <voltage>
VOUT?	Measures the supply's actual voltage output using the built-in voltage readback circuitry. Response: VOUT <voltage>
VRDAT <Vlo>,<Vhi>	Calculates and records the slope and offset for readback voltage using VRLO and VRHI data. Set CMODE ON before using this command. See also the calibration procedures in Section 4. <Vlo> and <Vhi> are in <voltage> format.

Continued on next page.



Table 3.5-1 Command Reference (continued)

Command	Description
VRHI	The power supply outputs a voltage value to an external voltmeter connected as part of the calibration procedure and records a voltage readback value internally. These values are at the high end of the programmed voltage range. Refer to the output value as VRHI and record it to use as input with the VRDAT command. Set CMODE ON before using this command. See also the calibration procedures in Section 4.
VRLO	The power supply outputs a voltage value to an external voltmeter connected as part of the calibration procedure and records a voltage readback value internally. These values are at the low end of the programmed voltage range. Refer to the output value as VRLO and record it to use as input with the VRDAT command. Set CMODE ON before using this command. See also the calibration procedures in Section 4.
VSET <voltage> or VSET <-voltage>	Sets the power supply's output voltage in volts (default) or in millivolts. This programmed voltage is the actual output in CV (constant voltage) mode or the voltage limit in CC (constant current) mode. If you enter a negative voltage value, the power supply will assert a signal on the J7-4 user signal line. You can use the user signal to trip external relays to switch the output polarity. Range: 0 to model maximum output voltage (VMAX) Initial value: 0 volts
VSET?	Asks for the power supply's present output voltage setting. Does not apply to voltage settings which are being held. See HOLD command. Response: VSET <voltage>

### 3.6 Accumulated Status, Status, and Fault Registers

The GPIB option card uses three separate registers which are always active. They are the accumulated status, status, and fault registers. You can use the status commands shown in Table 3.4-4 to activate the registers. The bit register has twelve conditions, each assigned a bit weight. When querying a register, the controller returns a response which is the sum of the weights of all relevant conditions.

**Example:** ASTS? Query the Accumulated Status register.

ASTS <771> Controller response.

771 = 512 + 256 + 2 + 1 = PON + REM + CC + CV

**Table 3.6-1 Accumulated Status, Status, and Fault Registers**

Condition	Mnemonic	Bit Position	Bit Weight
Constant voltage operation	CV	0	1
Constant current operation	CC	1	2
Not used	–	2	4
Overvoltage protection tripped	OV	3	8
Over heat protection tripped	OT	4	16
Supply external shutdown active (J7-1)	SD	5	32
Foldback mode operation	FOLD	6	64
Remote programming error	ERR	7	128
Power ON (accumulated status, status registers only)	PON	8	256
Remote mode (accumulated status, status registers only)	REM	9	512
AC fail condition	ACF	10	1024
Output fail condition	OPF	11	2048
Sense protection tripped	SNSP	12	4096

- Notes:
1. All mnemonics can be masked or unmasked.
  2. The error (ERR) bit is reset in the accumulated status, status, and serial poll registers with an error query (ERR?).
  3. The accumulated status register is cleared with an accumulated status query (ASTS?).
  4. A fault is cleared with a fault query (FAULT?).

### 3.7 Error Codes

If the ERR flag in the accumulated status or fault registers has been activated, an ERR? query will return an error number which corresponds to an event described in the following table. The ERR? query will also clear the ERR bit in the register.

**Table 3.7-1 Error Codes**

Error #	Error Identification	Explanation
0	No Errors	
4	Unrecognized Character	Received a character such as @,*,\$.
	Improper Number	Received a numeric character but the characters were not a proper number. Example: VSET ,±10.3
	Unrecognized String	Received an invalid command.
	Syntax Error	Received an incorrectly placed word, number, separator, or terminator. Example: OFF SRQ, VOUT 6, MASK, ERR
5	Number Out of Range	Specified a value for the command which was outside of the allowed range.
6	Attempt to Exceed Soft Limits	Attempted to program a voltage or current greater than the soft limit. Example: VMAX 500 ; VSET 550 LF
7	Improper Soft Limit	Attempted to program a soft limit less than the output value.
8	Data Requested without a Query Being Sent	The controller requested data from the power supply without first sending a query command.
9	OVP Set Below Output	Sent an OVSET command with a trip value lower than the output voltage.
10	Slave Processor Not Responding	The interface PCB slave processor did not respond.
12	Illegal Calibration	Attempted calibration when the supply was not in calibration mode. See CMODE command.

## 4. CALIBRATION

### 4.1 Introduction

#### WARNING

Exercise caution when using and servicing power supplies. High energy levels can be stored at the output voltage terminals on all power supplies in normal operation. In addition, potentially lethal voltages exist in the power circuit and the output connector of power supplies which are rated at 40 V and over. Filter capacitors store potentially dangerous energy for some time after power is removed.

You can calibrate the GPIB interface by adjusting the signal levels on the interface card so that they correspond to the expected signal levels on the power supply's main assembly. You may need to recalibrate the interface if you replace parts either on the interface board or on the main power supply board, or if the unit falls out of specification due to component aging drifts.

You can calibrate the GPIB Interface for:

- Voltage program
- Voltage readback
- Current program
- Current readback
- Overvoltage protection

The voltage calibration requires an external meter. The current calibration requires a shunt and meter. Set the CMODE (calibration mode) command to ON to activate calibration mode for the power supply. Refer to Section 3.5 Command Reference for more information about the calibration commands used in the following procedures.

The calibration procedures in this section are designed to be performed at an ambient temperature of  $25\text{ }^{\circ}\text{C} \pm 5\text{ }^{\circ}\text{C}$ .

## 4.2 Voltage Mode Calibration

### 4.2.1 Voltage Calibration Setup

1. Disconnect the load from the power supply which is to be calibrated.
2. Connect a voltmeter across the power supply's output terminals.

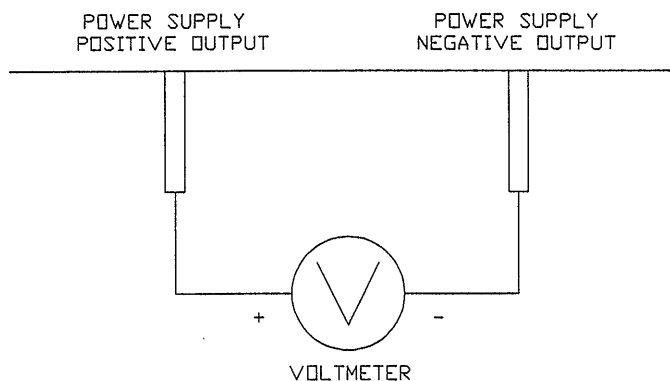

Figure 4.2-1 Voltage Calibration Setup

#### 4.2.2 Voltage Program Calibration Procedure

1. Set the power supply for calibration as in Section 4.2.1 Voltage Calibration Setup.
2. Activate calibration mode by sending command CMODE ON or CMODE 1 to the power supply.
3. Send command VLO; ILO to the power supply. Measure and record the output shown on the external voltmeter.
4. Send command VHI; IHI to the supply. Measure and record the output voltage as shown on the external voltmeter.
5. Send the command VDATA <vlo>,<vhi> where <vlo> and <vhi> are the values read from the voltmeter when the VLO and VHI commands were sent. When the power supply is calibrated, the low to high voltage program calibration values are stored as constants.
6. Program the supply at various levels using the VSET command to confirm that the calibration was successful and that linearity is observed. See the voltage program accuracy specification in Appendix A.
7. Turn off calibration mode by sending the command CMOD EOFF or CMO D E0 to the power supply.

#### 4.2.3 Voltage Readback Calibration Procedure

1. Set the power supply for calibration as in Section 4.2.1 Voltage Calibration Setup.
2. Activate calibration mode by sending command CMODE ON or CMODE 1 to the power supply.
3. Send command VRLO; IRLO to the power supply. Wait for the supply to settle. Measure and record the output shown on the external voltmeter. Send VRLO again.
4. Send VRHI; IRHI to the supply. Wait for the supply to settle. Measure and record the output voltage shown on the external voltmeter. Send VRHI again.
5. Send the command VRDAT <vlo>,<vhi> where <vlo> and <vhi> are the values read from the voltmeter after the VRLO and VRHI commands were sent. The processor calculates the offset value required to calibrate the power supply. When the power supply is calibrated, the low to high voltage readback calibration values (offsets) are stored as constants.
6. Use commands VSET and VOUT? commands to confirm that the calibration was successful and that linearity is observed. Refer to the voltage readback accuracy specification in Appendix A.
7. Turn off calibration mode by sending the command CMOD EOFF or CMO D E0 to the power supply.

## 4.3 Current Mode Calibration

### 4.3.1 Current Calibration Setup

1. Disconnect the load from the power supply to be calibrated.
2. Connect a shunt across the supply's output terminals.
3. Connect a voltmeter across the shunt.

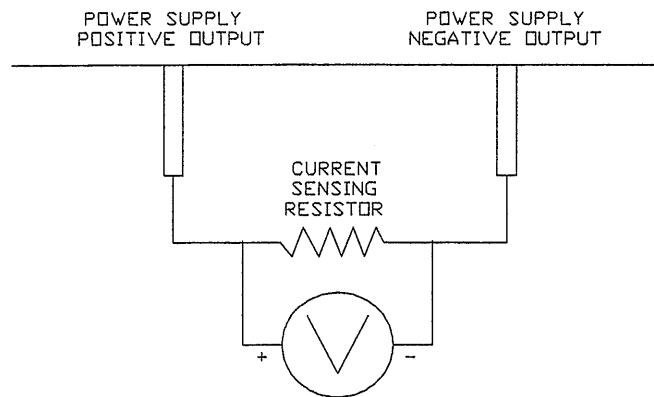

Figure 4.3-1 Current Calibration Setup

### 4.3.2 Current Program Calibration Procedure

1. Connect the shunt and voltmeter to the power supply as shown in Section 4.3.1 Current Calibration Setup.
2. Activate calibration mode by sending command `CMODE ON` or `CMODE 1` to the power supply.
3. Send command `ILO; VLO` to the power supply. Measure and record the output shown on the external voltmeter.
4. Send command `IHI; VHI` to the supply. Measure and record the output voltage shown on the external voltmeter.
5. Calculate `ILO` and `IHI` from the voltages read from the external voltmeter and the shunt resistance.  $I=V/R$ .
6. Send the command `IDATA <ilo>,<ihi>` to the power supply. `<ilo>` and `<ihi>` are the current values obtained from sending the `ILO` and `IHI` commands to the power supply. When the power supply is calibrated, the low to high current program calibration values are stored as constants.
7. Program the supply at various levels using the `ISET` command to confirm that the calibration was successful and that linearity is observed. Refer to the current program accuracy specification in Appendix A.
8. Turn off calibration mode by sending the command `CMOD EOFF` or `CMO D E0` to the power supply.

### 4.3.3 Current Readback Calibration Procedure

1. Connect the current shunt and voltmeter to the power supply as shown in Section 4.3.1.
2. Activate calibration mode by sending command CMODE ON or CMODE 1 to the power supply.
3. Send command IRLO; VRLO to the power supply. Wait for the supply to settle. Measure and record the output voltage shown on the external voltmeter. Send IRLO again.
4. Send command IRHI; VRHI to the supply. Wait for the supply to settle. Measure and record the output voltage shown on the external voltmeter. Send IRHI again.
5. Calculate IRLO and IRHI from the voltages taken from the external voltmeter and the shunt resistance.  $I=V/R$ .
6. Send the command IRDAT <ilo>,<ihi> to the power supply. <ilo> and <ihi> are the current values obtained from sending the IRLO and IRHI commands to the power supply. When the power supply is calibrated, the low to high current readback calibration values are stored as constants.
7. Program the supply at various levels using the ISET command to confirm that the calibration was successful and that linearity is observed. Refer to the current readback accuracy specification in Appendix A.
8. Turn off calibration mode by sending the command CMOD EOFF or CMO D E0 to the power supply.

## 4.4 Over Voltage Protection (OVP) Calibration

### CAUTION

If you remove the unit's cover, use proper static control techniques to avoid damage to static-sensitive components on the printed circuit board.

We recommend that you perform OVP calibration every six months. Connecting a digital voltmeter as in Section 4.2.1 is optional.

1. Disconnect all loads from the power supply.
2. Ensure that jumper J65 on the interface PCB is CLOSED to enable remote OVP calibration (Jumper J65 is closed at the factory).
3. Activate calibration mode by sending command CMODE ON or CMODE 1 to the power supply.
4. Send the command OVCAL to the power supply. The ADR LED will light during OVP calibration. Calibration is complete when the ADR LED turns off. This may take a few minutes.
5. Use the OVSET, OVSET?, and VSET commands to trip the OVP level, confirming that the calibration was successful. When you trip the OVP level, the red OVP LED will light and the voltage will drop to zero. Send the command RST to clear the OVP condition. Refer to the OVP program accuracy specification in Appendix A.
6. Turn off calibration mode by sending the command CMOD EOFF or CMO D E0 to the power supply.

## APPENDIX A. SPECIFICATIONS

The specifications in this section are warranted at 25 °C ±5 °C unless otherwise specified. All specifications are subject to change without notice.

### A.1 PVS 1200 Watt Series Supplies with GPIB Interface Installed

**Table A-1 Electrical Specifications for PVS 1200 Watt Series — 7.5 V to 60 V Models**

Models	7.5-140	12-100	20-60	40-30	60-20
<b>Program Resolution</b>					
Voltage	1.16 mV	1.8 mV	3.08 mV	6.2 mV	9.2 mV
Current	19.6 mA	14 mA	8.4 mA	4.2 mA	2.8 mA
OVP	1.16 mV	1.8 mV	3.08mV	6.2 mV	9.2 mV
<b>Program Accuracy<sup>1</sup></b>					
Voltage	10 mV ±0.12%	50 mV ±0.12%	75 mV ±0.12%	75 mV ±0.3%	150 mV ±0.25%
Current	500 mA ±0.1%	460 mA ±0.1%	250 mA ±0.1%	150 mA ±0.15%	120 mA ±0.1%
OVP	80 mV	150 mV	200 mV	400 mV	600 mV
<b>Readback Resolution</b>					
Voltage	1.16 mV	1.8 mV	3.08 mV	6.2 mV	9.2 mV
Current	19.6 mA	14 mA	8.4 mA	4.2 mA	2.8 mA
<b>Readback Accuracy<sup>2</sup></b>					
Voltage	30 mV ±0.12%	60 mV ±0.12%	75 mV ±0.12%	75 mV ±0.3%	150 mV ±0.25%
Current	500 mA ±0.1%	460 mA ±0.1%	250 mA ±0.1%	150 mA ±0.15%	120 mA ±0.1%

1. Apply accuracy specifications according to the following voltage program accuracy example:  
Set a model PVS 20-60 power supply to 10volts.  
The expected result will be within the range of 10volts ±75mV ±0.12% of the set voltage of 10volts.
2. See Footnote 1.

**Table A-2 Electrical Specifications for PVS 1200 Watt Series — 100 V to 600 V Models**

Models	100-12	150-8	300-4	600-2
<b>Program Resolution</b>				
Voltage	15.4 mV	23.1 mV	46.2 mV	92.4 mV
Current	1.68 mA	1.12 mA	0.56 mA	0.28 mA
OVP	15.4 mV	23.1 mV	46.2 mV	92.4 mV
<b>Program Accuracy<sup>1</sup></b>				
Voltage	150 mV ±0.35%	225 mV ±0.35%	225 mV ±0.35%	250 mV ±0.35%
Current	80 mA ±0.1%	80 mA ±0.1%	80 mA ±0.1%	50 mA ±0.1%
OVP	800 mV	1.5 V	3.0 V	6 V
<b>Readback Resolution</b>				
Voltage	15.4 mV	23.1 mV	46.2 mV	92.4 mV
Current	1.68 mA	1.12 mA	0.56 mA	0.28 mA
<b>Readback Accuracy<sup>2</sup></b>				
Voltage	150 mV ±0.35%	225 mV ±0.35%	225 mV ±0.35%	250 mV ±0.35%
Current	80 mA ±0.1%	80 mA ±0.1%	80 mA ±0.1%	50 mA ±0.1%

1. Apply accuracy specifications according to the following voltage program accuracy example:  
Set a model PVS 20-60 power supply to 10volts.  
The expected result will be within the range of 10 volts ± 75mV ± 0.12% of the set voltage of 10 volts.
2. See Footnote 1.



## A.2 PVS 2800 Watt Series Supplies with GPIB Interface Installed

**Table A-1 Electrical Specifications for PVS 2800 Watt Series — 7.5 V to 60 V Models**

Models	7.5-300	12-220	20-130	40-70	60-46
Program Resolution					
Voltage	1.16 mV	1.8 mV	3.08 mV	6.2 mV	9.2 mV
Current	42.0 mA	30.8 mA	18.2 mA	9.8 mA	6.44 mA
OVP	1.16 mV	1.8 mV	3.08 mV	6.2 mV	9.2 mV
Program Accuracy <sup>1</sup>					
Voltage	10 mV ±0.12%	50 mV ±0.12%	75 mV ±0.12%	75 mV ±0.3%	150 mV ±0.25%
Current	900 mA ±0.1%	750 mA ±0.1%	500 mA ±0.1%	350 mA ±0.1%	250 mA ±0.1%
OVP	80 mV	150 mV	200 mV	400 mV	600 mV
Readback Resolution					
Voltage	1.16 mV	1.8 mV	3.08 mV	6.2 mV	9.2 mV
Current	42.0 mA	30.8 mA	18.2 mA	9.8 mA	6.44 mA
Readback Accuracy <sup>2</sup>					
Voltage	30 mV ±0.12%	60 mV ±0.12%	75 mV ±0.12%	75 mV ±0.3%	150 mV ±0.25%
Current	900 mA ±0.1%	750 mA ±0.1%	500 mA ±0.1%	350 mA ±0.1%	250 mA ±0.1%

- Apply accuracy specifications according to the following voltage program accuracy example:  
Set a model PVS 20-60 power supply to 10volts.  
The expected result will be within the range of 10volts ±75mV ±0.12% of the set voltage of 10volts.
- See Footnote 1.

**Table A-2 Electrical Specifications for PVS 2800 Watt Series — 100 V to 600 V Models**

Models	100-28	150-18	300-9	600-4
Program Resolution				
Voltage	15.4 mV	23.1 mV	46.2 mV	92.4 mV
Current	3.92 mA	2.52 mA	1.26 mA	0.56 mA
OVP	15.4 mV	23.1 mV	46.2 mV	92.4 mV
Program Accuracy <sup>1</sup>				
Voltage	150 mV ±0.35%	225 mV ±0.35%	225 mV ±0.35%	250 mV ±0.35%
Current	140 mA ±0.15%	120 mA ±0.1%	80 mA ±0.1%	80 mA ±0.1%
OVP	800 mV	1.5 V	3.0 V	6 V
Readback Resolution				
Voltage	15.4 mV	23.1 mV	46.2 mV	92.4 mV
Current	3.92 mA	2.52 mA	1.26 mA	0.56 mA
Readback Accuracy <sup>2</sup>				
Voltage	150 mV ±0.35%	225 mV ±0.35%	225 mV ±0.35%	250 mV ±0.35%
Current	140 mA ±0.15%	120 mA ±0.1%	80 mA ±0.1%	80 mA ±0.1%

- Apply accuracy specifications according to the following voltage program accuracy example:  
Set a model PVS 20-60 power supply to 10volts.  
The expected result will be within the range of 10volts ±75mV ±0.12% of the set voltage of 10volts.
- See Footnote 1.

## APPENDIX B. SAMPLE PROGRAM

The following sample program is written in Microsoft Visual Basic for a setup which includes National Semiconductor's NI-488.2 GPIB board.

```
-----  
Dim rd As Integer  
Call ibfind(DEV2 rd)           Address the GPIB device  
Call ibconfig(rd 6 1)        Set the device configuration (enables repeat addressing).
```

Get the model information. (When you do not enable repeat addressing in the device configuration, the unit will not switch from local to remote mode.)

```
-----  
Dim strModelInfo As String  
StrModelInfo = Space(128)  
Call ibwrt(rd ID)             Check the model information.  
Call ibrd(rd strModelInfo)    Store the model information in the readout variable.  
MsgBox Left(strModelInfo ibcntl) Display the information.
```

```
-----  
Call ibwrt(rd VSET 5)         Set the voltage to 5 and the current to 1.  
Call ibwrt(rd ISET 1)  
Call ibwrt(rd OUT ON)  
Call ibwrt(rd VOUT?)
```

```
-----  
Dim strVoutValue As String    Read back the voltage output and display it on the screen.  
Call ibrd(rd strVoutValue)  
StriVoutValue = Mid(strVoutValue 5)  
Dim iVoutValue As Integer  
iVoutValue = Val(strVoutValue)  
MsgBox VOUT = + Str(iVoutValue)
```